

OPTIONAL OPCIONAL OPTIONEEL ДОПОЛНИТЕЛЬНО

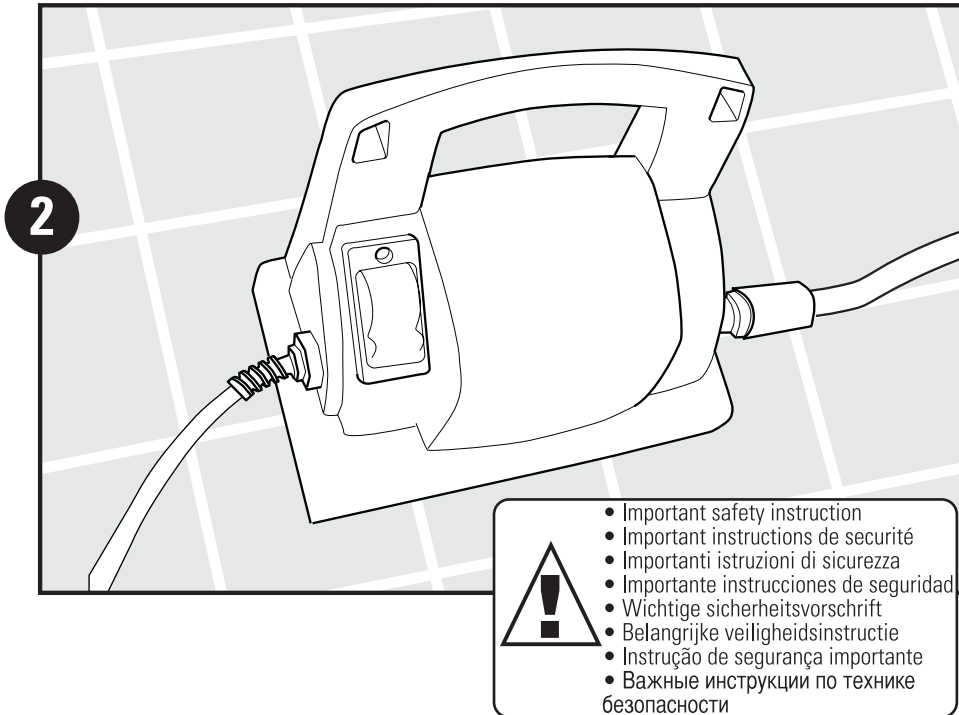

- Keep power supply out of standing water
- Ne pas poser le boîtier électrique sur une surface humide
- Tenere l'alimentatore distante dall'acqua stagnante
- No poner el transformador sobre una superficie húmeda
- Halten sie die stromversorgung von stehendem wasser fern
- Plaats de stroomtoevoer nooit in het water
- Manter a fonte de alimentação longe de água estagnada
- Избегать попадания воды в область системы электропитания

- Use only original Diagnostic Basic power supply - factory wired for 100/115/230 vac mains supply
- N'utilisez que le boîtier original Diagnostic Basic - câblée en usine pour un e alimentation secteur de 100/115/230 vac
- Usare solo l'alimentatore elettrico originale Diagnostic Basic - predisposto in fabbrica per alimentazione rete a 100/115/230 vca
- Utilice solamente fuente de alimentación de Diagnóstico Basic - cableado en fábrica para alimentar redes de 100/115/230 vca
- Benutzen sie nur die Diagnostic Basic-stromversorgung - fabrikfertig für 100/115/230 vac-netzanschluss
- Gebruik alleen de originele Diagnostic Basic elektriciteitsaanvoer - de fabriekskabel is geschikt voor 100/115/230 vac elektriciteit
- Utilize somente Fonte de Alimentação original de Diagnostic Basic - Ligação feita em fábrica para rede de energia elétrica de 100/115/230 VCA
- Использовать только оригинальную систему электропитания - заводская проводка рассчитана на сеть 100/115/230 В переменного тока



Caddy Assembly Instructions

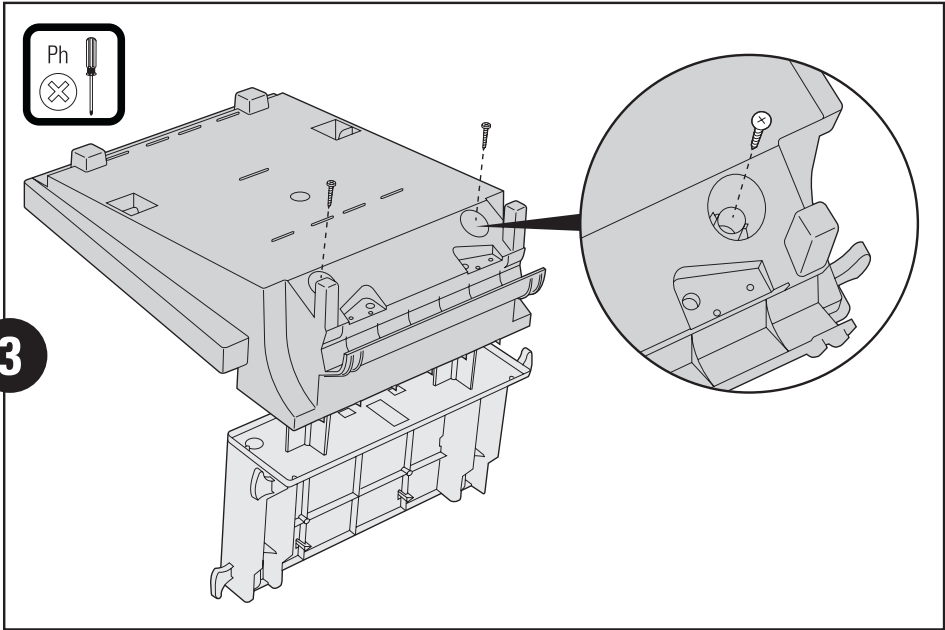

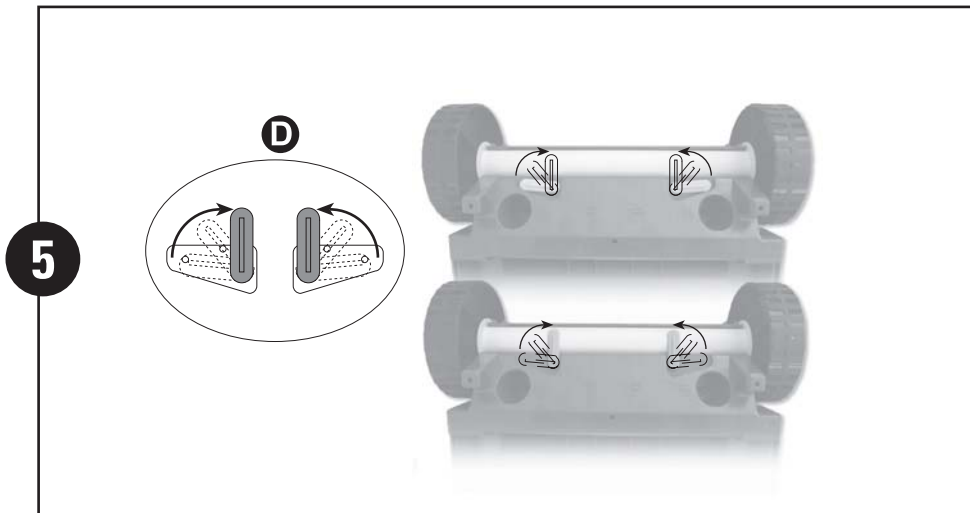
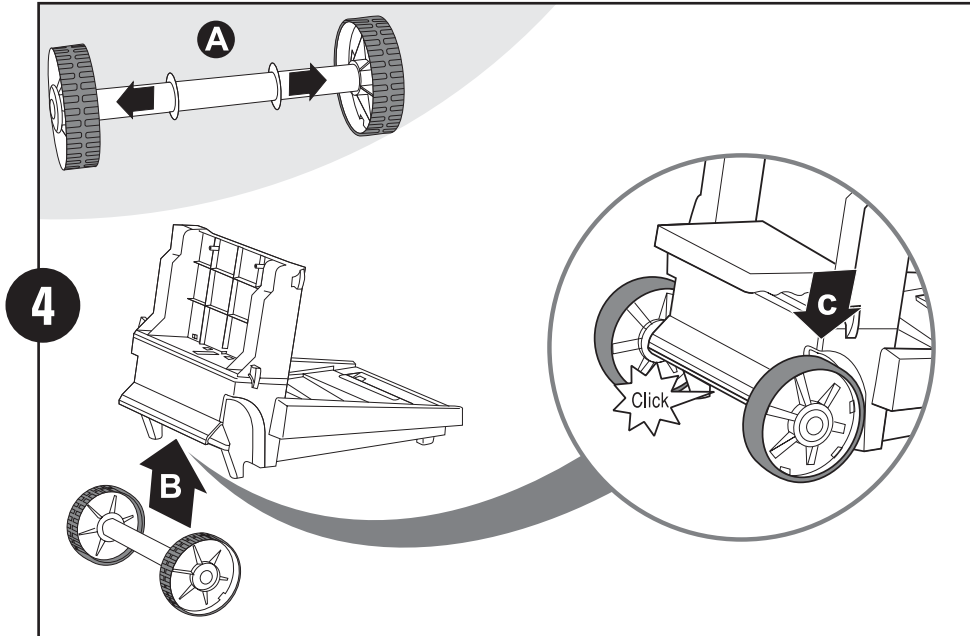

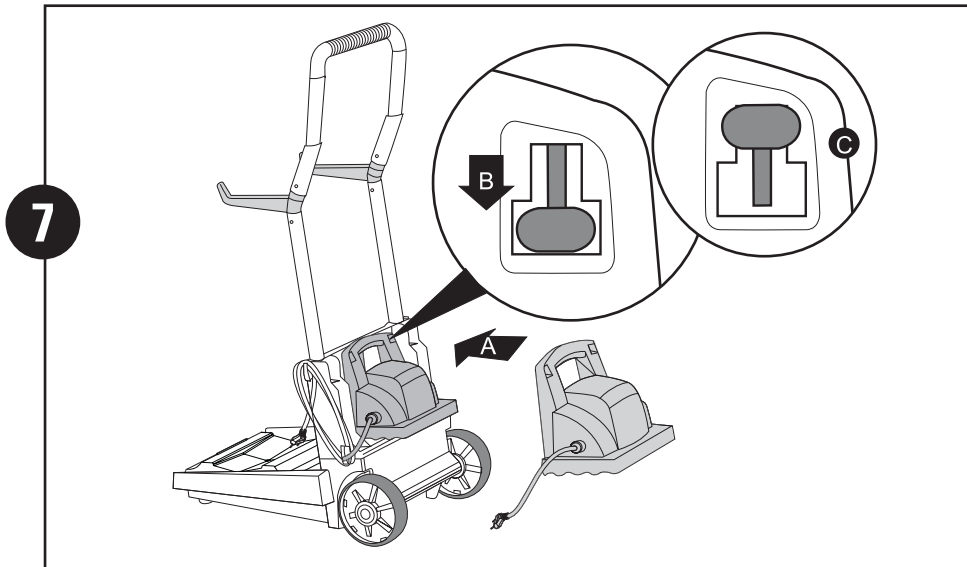
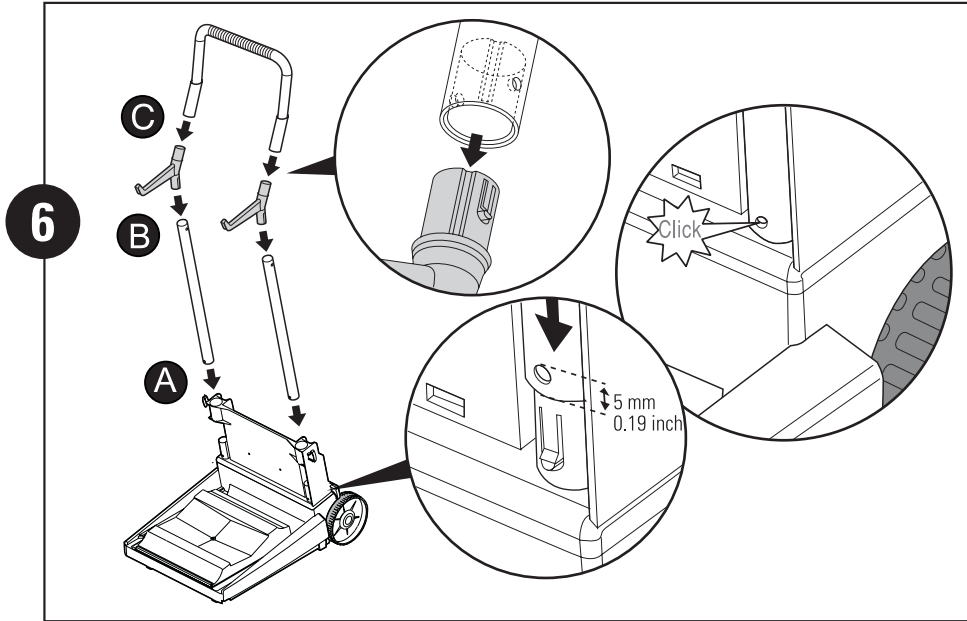

8

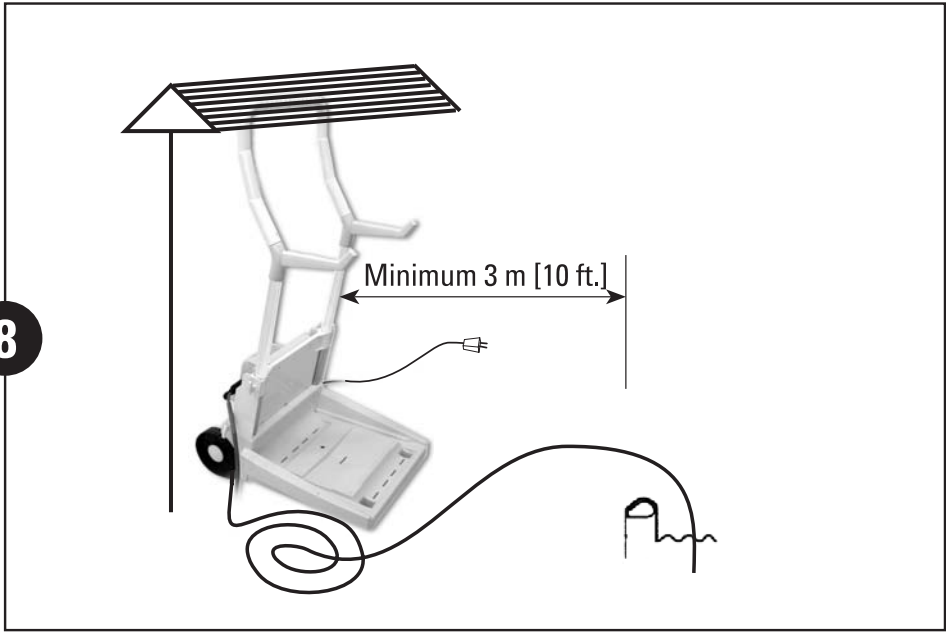

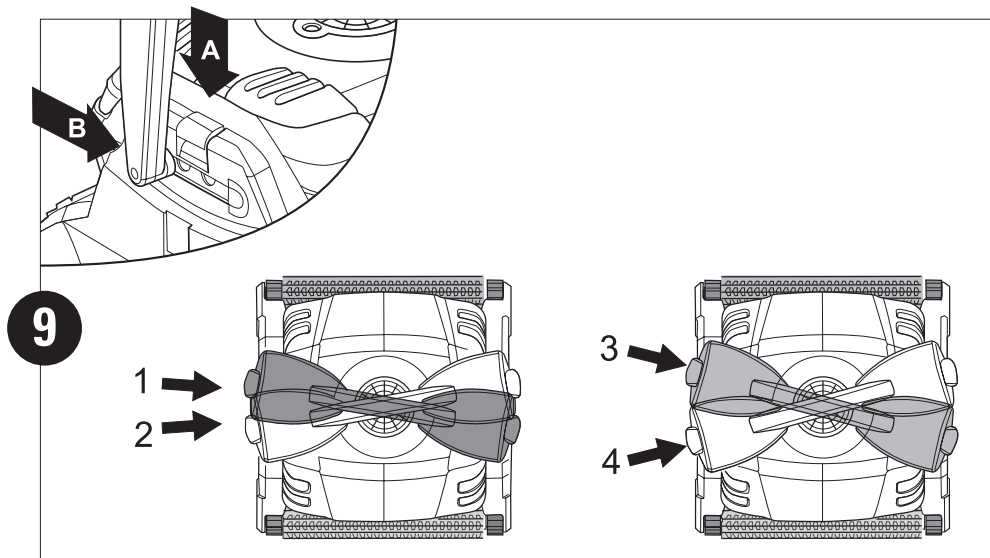

Change diagonal handle positions after every cleaning cycle:
 1 and 2 - slow waterline sideways movement. 3 and 4 - fast waterline sideways movement

Changer les positions des poignées de diagonales après le cycle de nettoyage:
 1 et 2 – ralentir le mouvement latéral de la ligne d'eau. 3 et 4 – accélérer le mouvement latéral de la ligne d'eau

Verander de diagonale handvat posities na iedere schoonmaak cyclus:
 1 en 2 – langzame zijwaartse bewegingen op de waterlijn. 3 en 4 – snelle zijwaartse bewegingen op de waterlijn

Cambie las posiciones diagonales de la manija después de cada ciclo de limpieza:
 1 y 2 - movimiento lateral lento de la línea de flotación. 3 y 4 - movimiento lateral rápido de la línea de flotación

Ändern Sie die diagonale Griffpositionen nach jedem Reinigungszyklus:
 1 und 2 – langsame Seitwärtsbewegungen an der Wasserlinie. 3 und 4 – schnelle Seitwärtsbewegungen an der Wasserlinie

Modificare le posizioni dell'impugnatura diagonale alla fine di ogni ciclo di pulizia:
 1 e 2 - movimento lento lungo le linee laterali di livello dell'acqua. 3 e 4 - movimento veloce lungo le linee laterali di livello dell'acqua

Mude as posições diagonais da pega após cada ciclo de limpeza:
 1 e 2 - movimento lateral lento da linha de flutuação. 3 e 4 - movimento lateral rápido da linha de flutuação

После каждого цикла очистки следует изменять горизонтальное положение ручки
 1 и 2 – медленное боковое движение уровня воды 3 и 4 - быстрое боковое движение уровня воды



- If pva rings / wonder rings are dry, soak them in water until soft
- Si les brosses pva / wonder sont secs, trempez-les dans l'eau jusqu'à ce qu'ils redeviennent mous
- Se gli anelli pva / gli anelli mobili sono asciutti, ammollarli in acqua finché diventano soffici
- Si los anillos pva / anillos wonder están secos, remójelos en agua hasta que se ablanden
- Aenn die pva-ringe/wunderringe trocken sind, tränken sie sie mit wasser, bis sie weich werden
- Als de pva ringen/wonder ringen droog zijn, weekt u ze in water totdat ze zacht zijn geworden
- Se os anéis de pva/anéis wonder secarem, molhe-os em água até ficarem maleáveis
- В СЛУЧАЕ, ЕСЛИ КОЛЬЦА ПВА ИЛИ ПОДВИЖНЫЕ КОЛЬЦА СУХИЕ, СЛЕДУЕТ ПОДЕРЖАТЬ ИХ В ВОДЕ ДО ТЕХ ПОР, ПОКА ОНИ НЕ СТАНУТ МЯГКИМИ

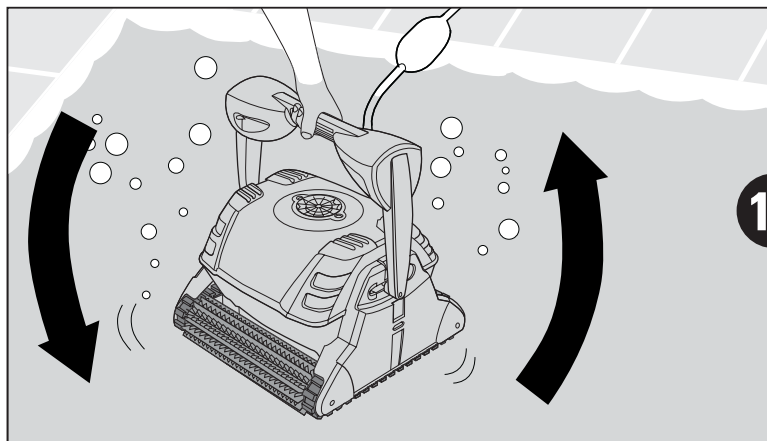

CHLORINE
2 - 4 ppm

PH
7 - 7.4

32°C 90°F
12°C 54°F

NaCl
max
4000 ppm

- Shake robot from side to side or turn it upside down to release trapped air
- Secouez le robot sur les côtés ou de haut en bas pour libérer les bulles d'air
- Scuotere il robot di da un lato all'altro o girarlo a testa in giù per liberarne l'aria imprigionata
- Sacuda el robot de lado a lado o póngalo boca arriba para soltar el aire retenido
- Schwenken sie den roboter von seite zu seite oder kippen sie ihn um, um den lufteinschluss zu befreien
- Schud de robot heen en weer, of houd hem onderste boven om vastgelopen lucht vrij te laten
- Sacudir o robô lateralmente ou virar de cima para baixo para liberar ar confinado
- Потрясти робот из стороны в сторону или перевернуть его для удаления скопившегося внутри воздуха

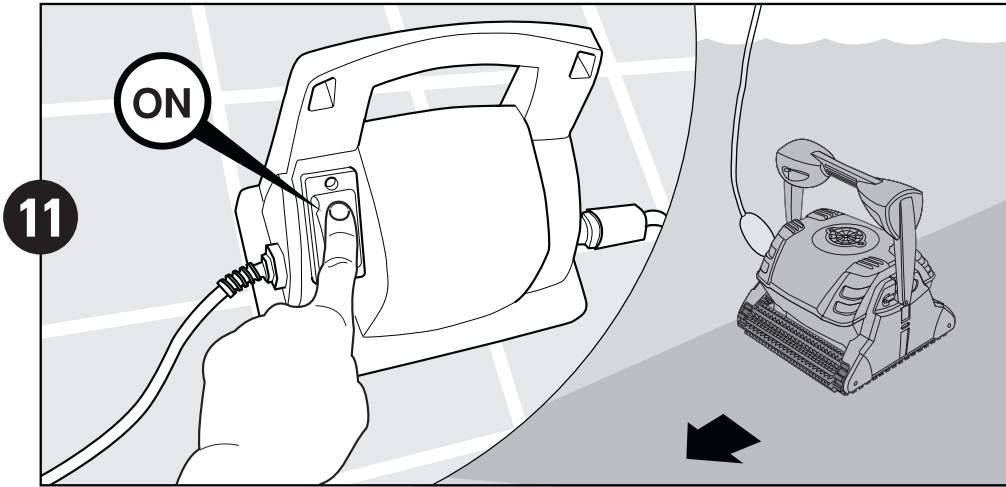



- Robot will perform automatic shut-off at the end of the cleaning cycle
- Le robot s'éteindra automatiquement à la fin du cycle de nettoyage
- Il robot si disattiverà automaticamente alla fine del ciclo di pulizia
- El robot efectuará el apagado automático al término del ciclo de limpieza
- Der roboter wird am ende des waschzyklus automatisch abschalten
- De robot slaat automatisch af aan het einde van de schoonmaak cyclus
- O robô desligará automaticamente no fim do ciclo de limpeza
- Робот автоматически отключает систему по завершении цикла очистки.

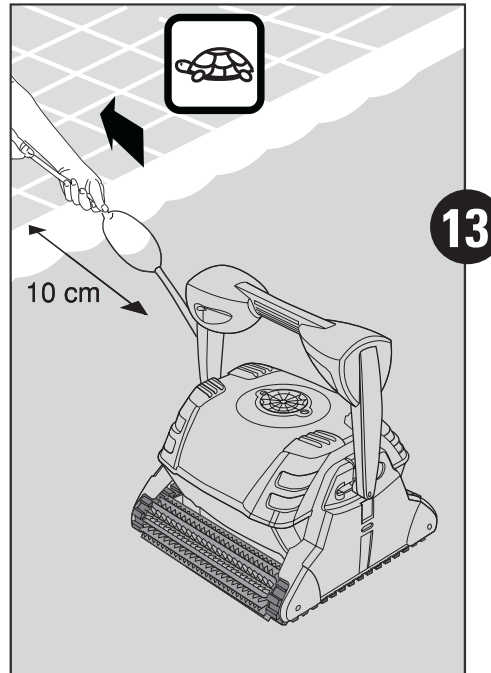
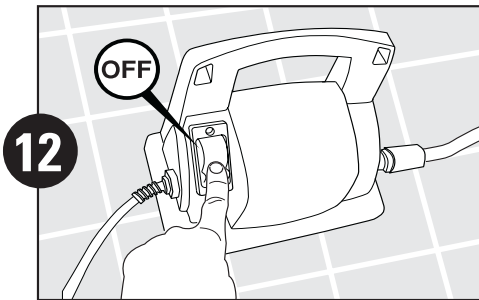

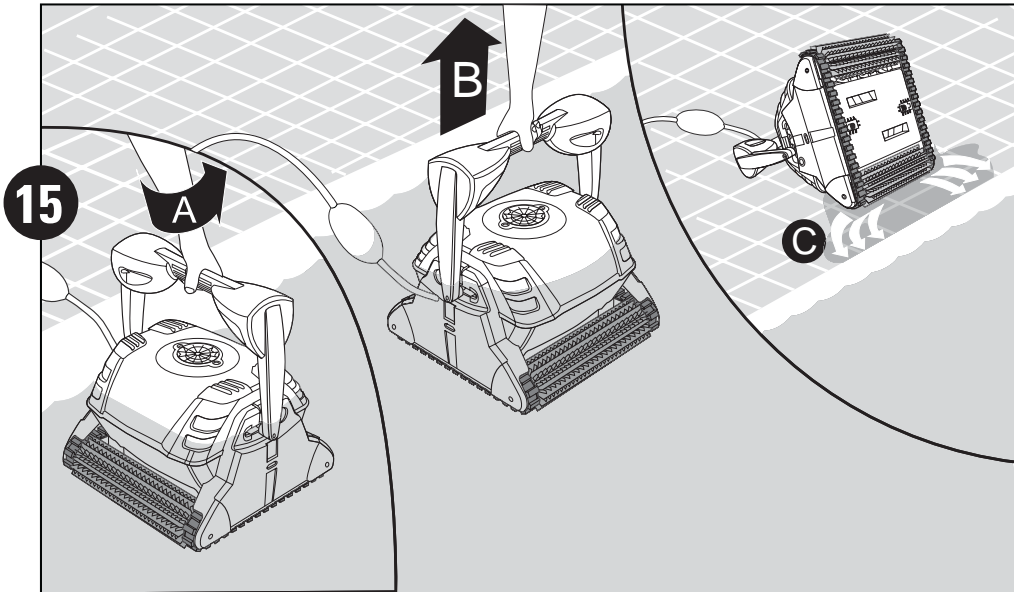
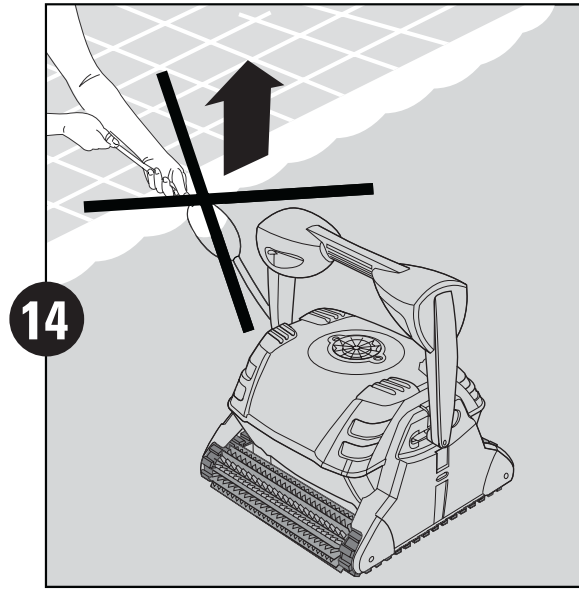

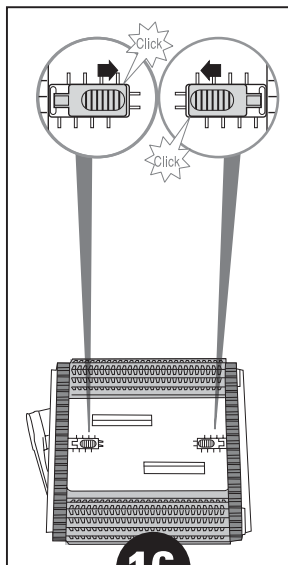

16

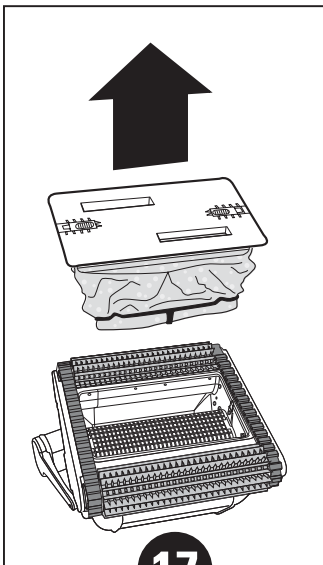

17

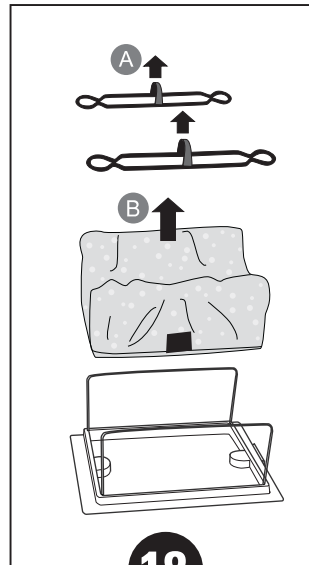

18

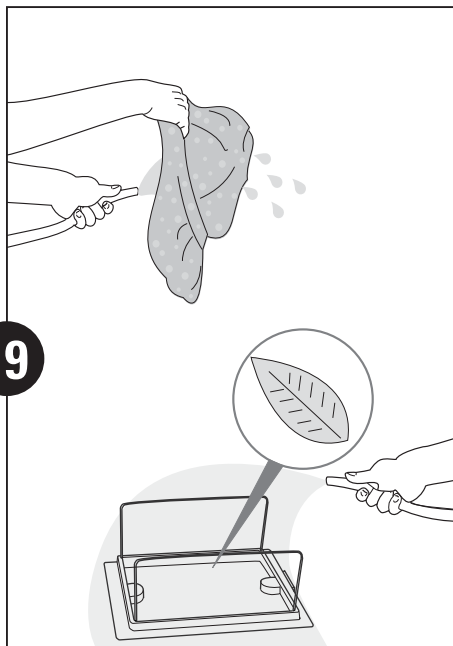

19

- It is recommended to periodically wash filter bag in a washing machine. Use synthetic cleaning program
- Il est recommandé de laver périodiquement le filtre dans la machine à laver. Utilisez le programme de nettoyage synthétique
- È raccomandabile lavare periodicamente il sacchetto-filtro in una macchina lavatrice. Selezionare un programma di lavaggio per materiali sintetici
- Se recomienda lavar periódicamente la bolsa del filtro en una máquina lavadora. Utilice el programa para el lavado de fibras sintéticas
- Es ist empfehlenswert, den filterbeutel regelmäßig in einer waschmaschine zu waschen. Betätigen sie ein synthetisches waschprogramm
- Aanbevolen wordt om de filterzak regelmatig in de wasmachine met een syntetisch wasprogramma te wassen
- Recomenda-se lavar periodicamente o saco de filtragem em uma máquina de lavar. Utilize o programa de limpeza sintética
- Рекомендуется периодически промывать мешок фильтра в стиральной машине. Использовать программу для стирки синтетических материалов.

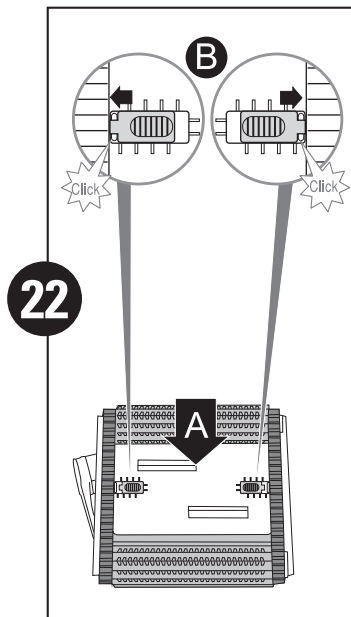
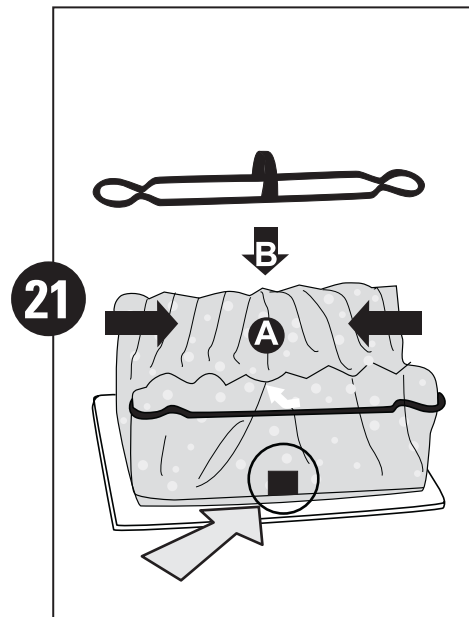
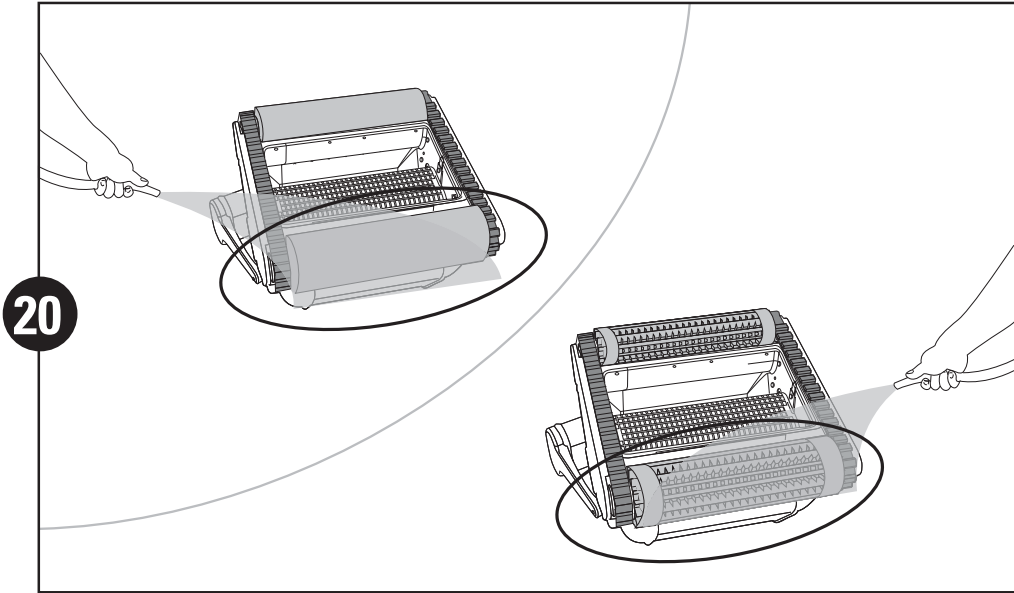

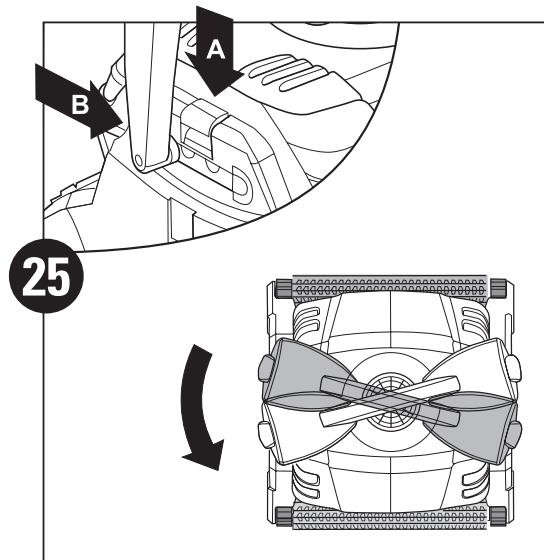
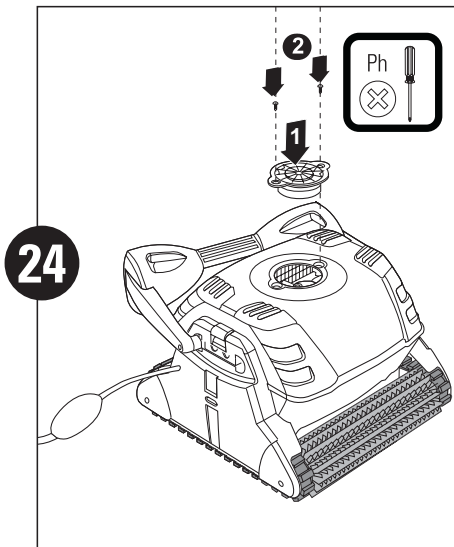
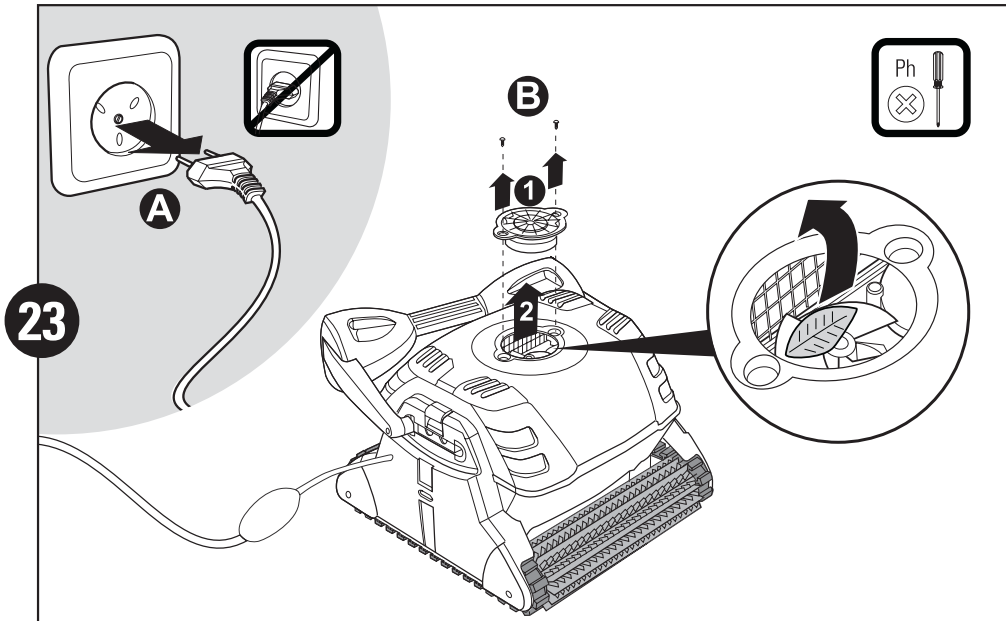

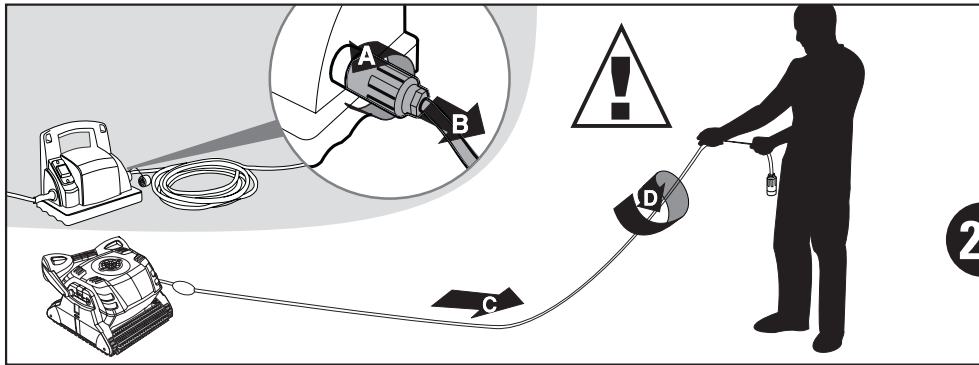

26

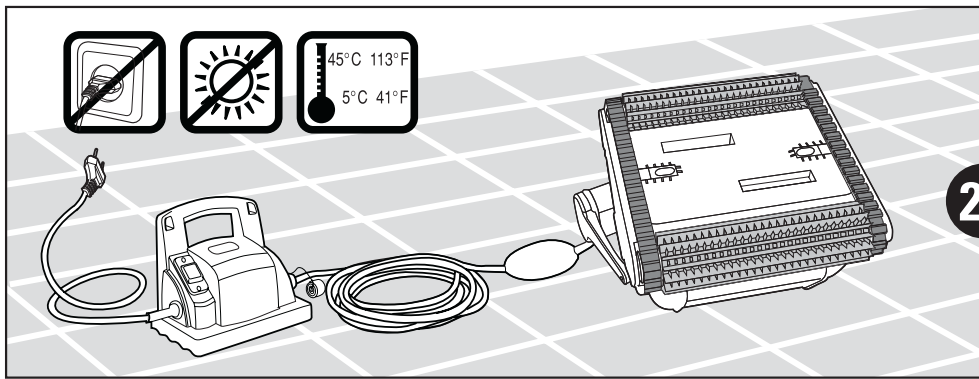

27

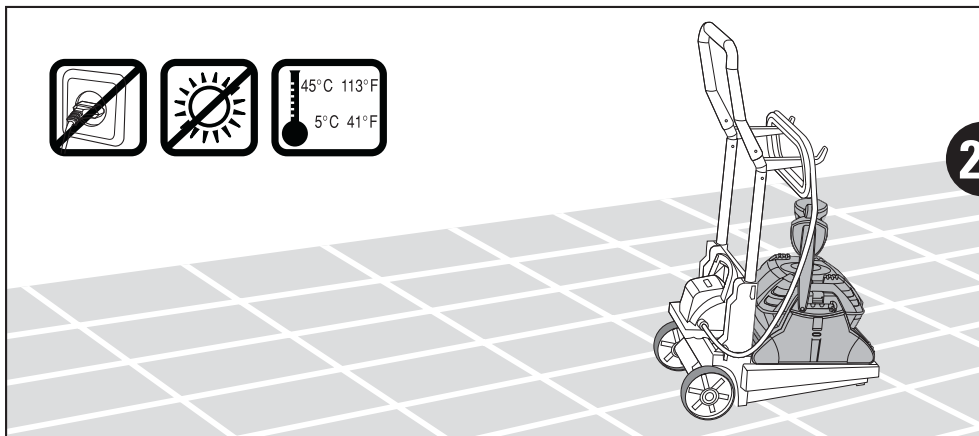

28

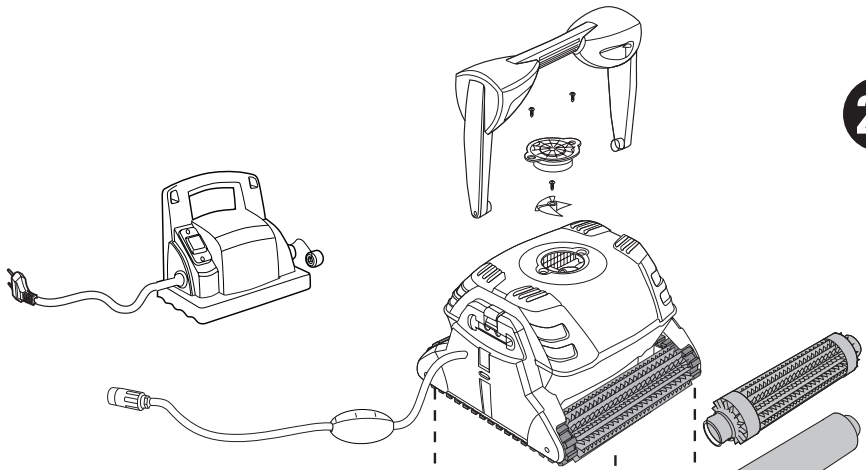

OPTIONAL OPCIONAL OPTIONEEL ДОПОЛНИТЕЛЬНО

